

DIPLOMA EXAMINATION IN ENGINEERING/TECHNOLOGY/  
MANAGEMENT/COMMERCIAL PRACTICE — OCTOBER, 2017

MACHINE DRAWING

[Time : 3 hours

(Maximum marks : 100)

- [Note:—1. All dimensions are in mm.  
2. First angle projections is to be followed.  
3. Missing data if any may be suitably assumed.  
4. Both sides of the drawing sheet may be used.  
5. Sketches accompanied.]

UNIT — I

- |  | Marks |
|--|-------|
| I Draw three views of a hexagonal headed bolt of size M 24. The length of the bolt is 80 mm and thread length is 54 mm. Indicate all dimensions on the drawing in terms of diameter of the bolt. | 15    |
| OR   |       |
| II Draw the following rivet heads in proportional dimension<br>(a) Pan head (b) Mushroom head (c) Rounded countersunk head   | 15    |

UNIT — II

- |  |    |
|--|----|
| III Pictorial view of a Knuckle joint is shown in figure I. Draw top half sectional elevation and end view from left side.                   | 30 |
| OR   |    |
| IV An isometric view of a flexible bush type coupling shown in Figure II. Draw the top half sectional elevation and end view from left side. | 30 |

UNIT — III

- |  |    |
|--|----|
| V Detailed views of a foot step bearing shown in figure III. Assemble the parts and draw full sectional front view and top view.                   | 40 |
| OR   |    |
| VI Full sectional front view of a Non return valve shown in figure IV. Draw the left half sectional front view and bottom half sectional top view. | 40 |

## UNIT — IV

VII Draw the following welded joints

- (a) Butt joint
- (b) Lap joint
- (c) Tee joint
- (d) Corner joint
- (e) Edge joint

15

OR

VIII Draw the double line orthographic symbol of the following pipe fittings.

- (a) 45° Elbow
- (b) Tee
- (c) Reducer
- (d) Plug
- (e) Hose nipple

15

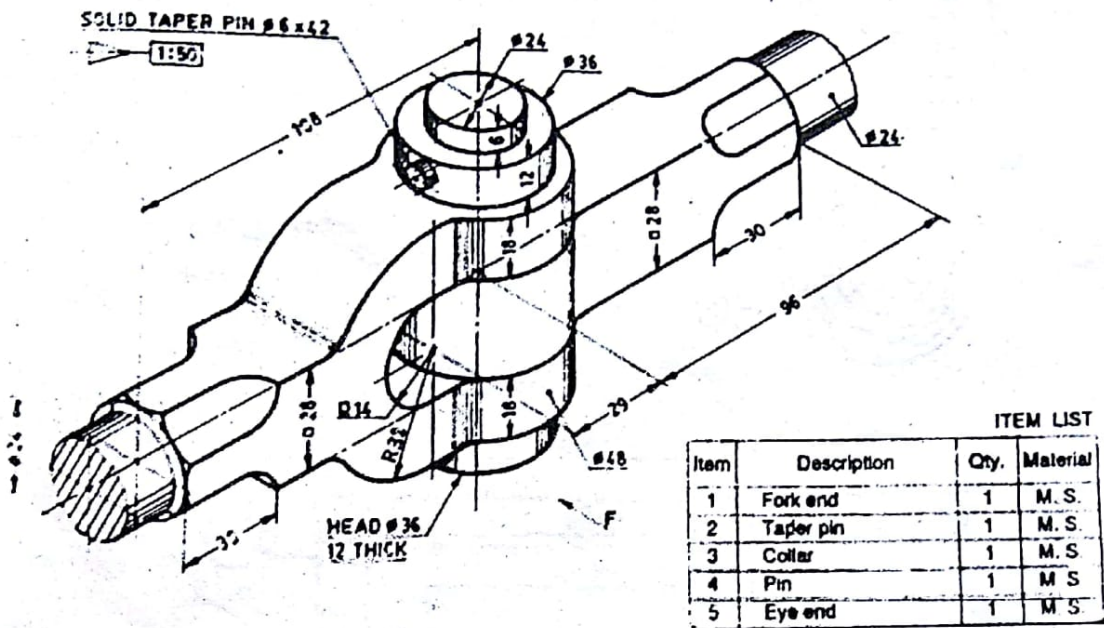

Figure I Knuckle joint

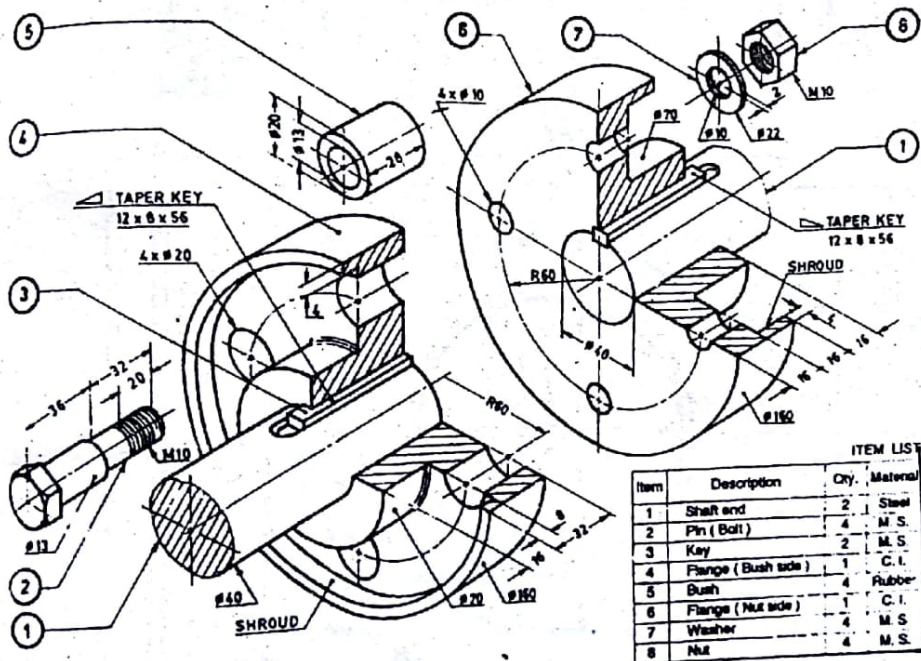

Fig. II Flexible bush type coupling

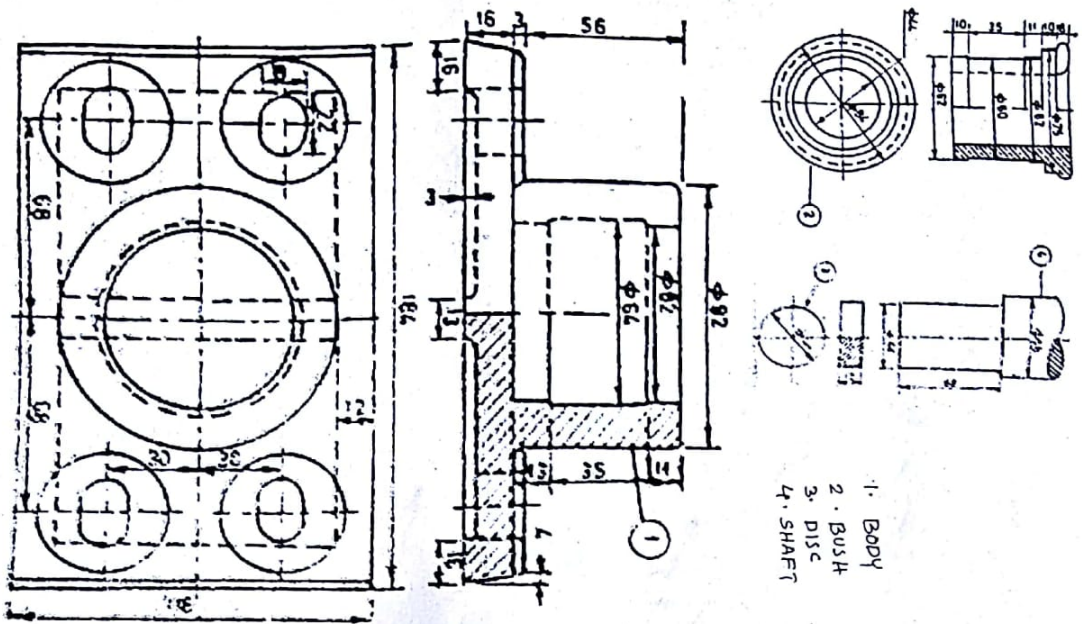

Fig. III Details of foot step bearing

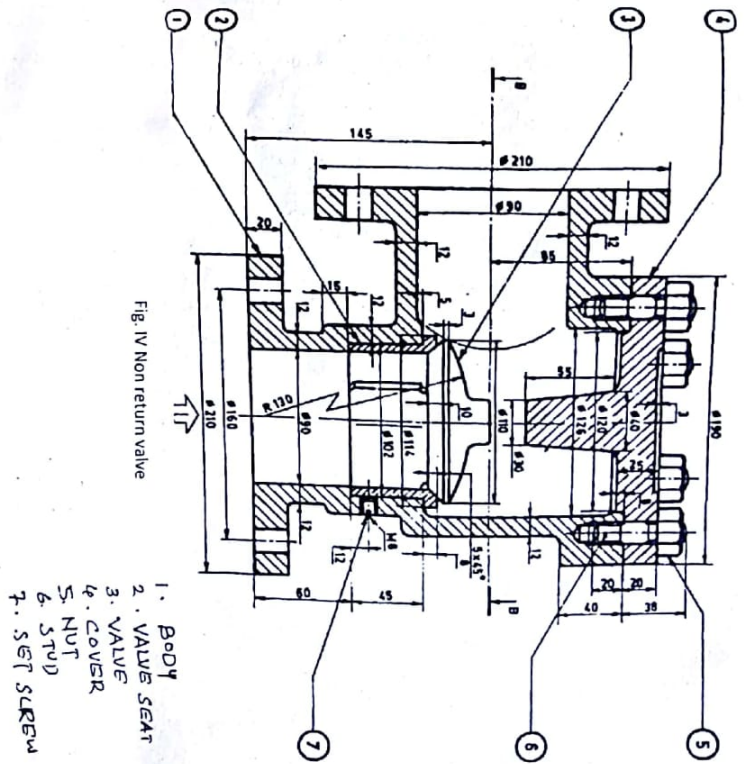

Fig. IV Non return valve