

**MODEL QUESTION PAPER**

TED (15) 2005

Reg. No.....

(REVISION - 2015)

Signature. -----

SECOND SEMESTER DIPLOMA EXAMINATION IN ENGINEERING/ TECHNOLOGY

**ENGINEERING GRAPHICS**

(Common to all branches except DCP and CABM)

[ Time : 3 hours

[Note : 1. Missing data if any suitably assumed

2. Sketches to be accompanied ]

**PART- A**

(Maximum marks: 10)

Marks

I Answer the following questions in one or two sentences. Each question carries 2 marks.

1. Write any four elements of dimensioning.

2. Why do you require sectional view of an object?

3. What are the four coordinate system used in CAD for drawing line.

4. Define cycloid.

5. What do you mean by cabinet oblique projection?

(5x2=10)

**PART- B**

(Maximum marks : 50)

(Answer any five of the following questions. Each question carries 10 marks.)

II Redraw the given figure 1 and dimension as per BIS.

III The profile of an automobile lamp reflector is in the form of parabola. The maximum rim diameter of the reflector is 70 mm and the depth is 48 mm. Draw the shape of the parabola.

IV The distance between two station is 100 Km and on a road map it is shown by 30 cm. Draw a

Diagonal scale and indicate a distance of 46.8 Km.

V Projections of various points is given in figure 2. State the position of position of each point with respect to HP and VP

VI The top view of 75 mm long line AB measures 65 mm while the length of its front view is 50 mm. It's one end A is in the HP and 12 mm in front of VP. Draw the projection of line AB and determine its inclination with the HP and VP.

VII. A circular lamina of 50 mm diameter inclined at  $30^{\circ}$  to HP and perpendicular to VP has its center 30 mm in front of VP and on HP draw its front view and top view.

VIII Draw the development of the elbow shown in fig. 3 (5x10=50)

#### PART-C

(Maximum marks: 40)

(Answer any two of the following questions. Each question carries 20 marks)

IX. Figure 3 shows the pictorial view of a block. Draw its front view in the direction of the arrow F and top view

X. The isometric view of a bracket shown in figure 5. Draw the front view in the direction of arrow F, top view and auxiliary projection of the inclined surface.

XI. The orthographic view of a stopper shown in figure 6. Draw oblique projection by cavalier method.

(2x20=40)

-----

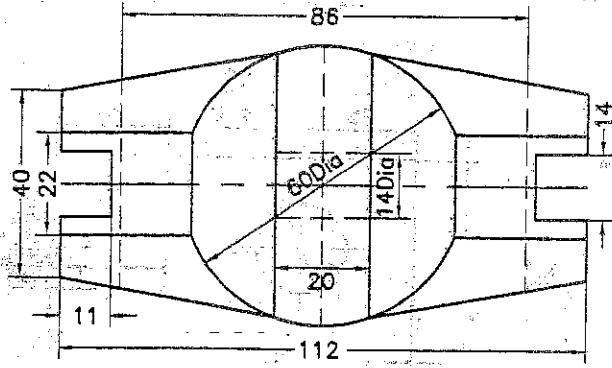

Fig-1

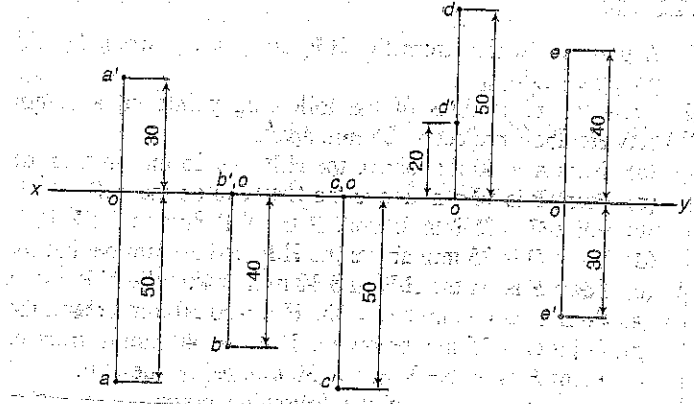

Fig-2

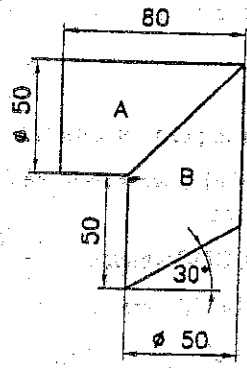

Fig-3

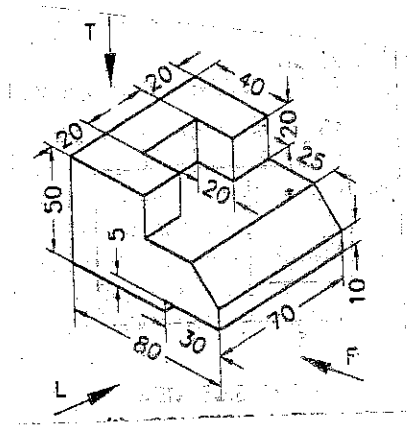

Fig-4

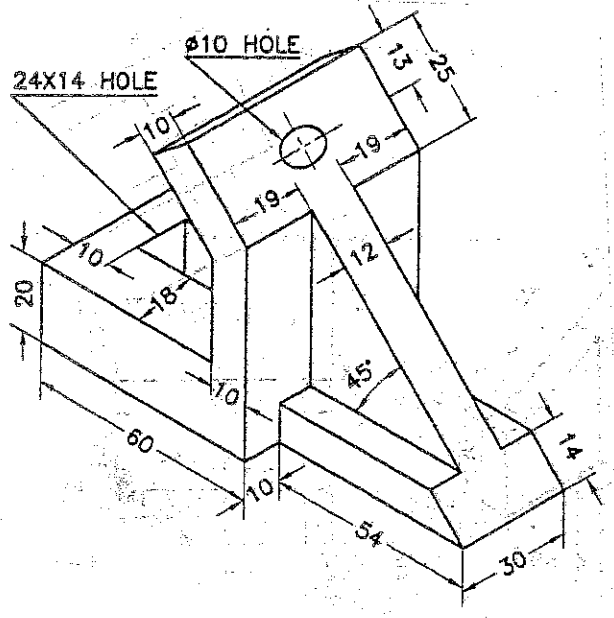

Fig-5

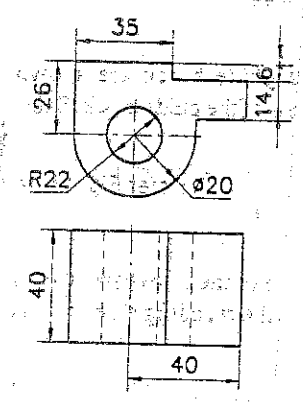

Fig-6